

POWERMITE

SHARPS
Est. 1967
ELECTRICAL

FESTOON SYSTEMS FOR MOBILE MACHINERY

C-Track Cable Festoon System

Suitable for round and flat cables, hoses, fibre optics, curtains and other applications

Connecting Africa

a member of the **Hudaco** group

5 FLAT CABLE CARRIER NO.90

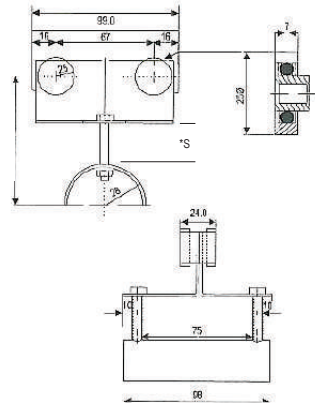
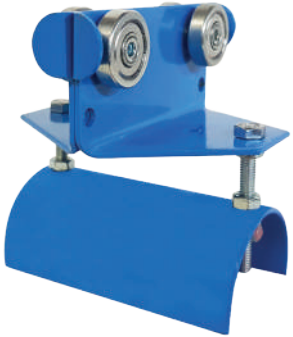

PART NO.	DESCRIPTION
P6565	FLAT CABLE CARRIER NO.90
P6685	FLAT CABLE CARRIER NO.90, ss 304

*P6565 are ZZ Bearings. *P6685 are S/Steel RS Bearings.

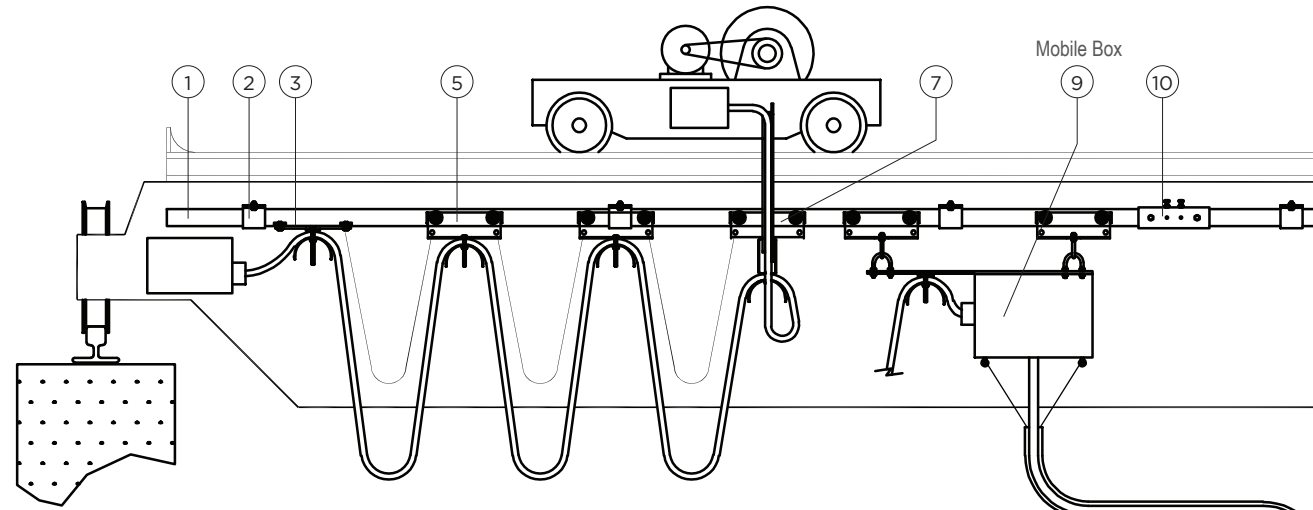

3 END CLAMP NO.92

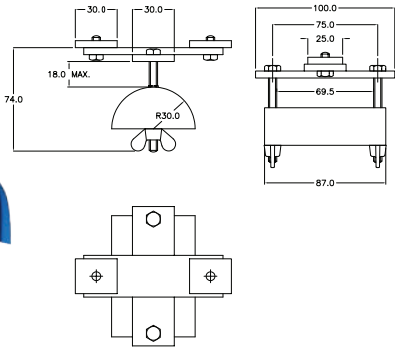

PART NO.	DESCRIPTION
P6567	FLAT END CLAMP NO.92
P6687	FLAT CABLE END CLAMP NO.92, ss 304

7 MASTER CARRIER NO.91

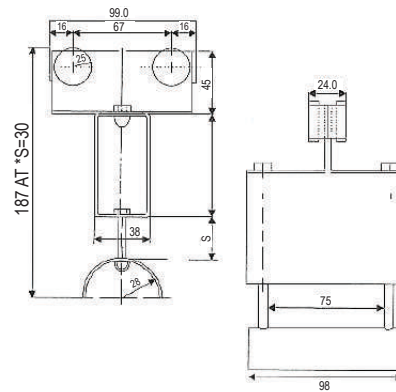

PART NO.	DESCRIPTION
P6566	FLAT MASTER CARRIER NO.91
P6686	FLAT MASTER CABLE CARRIER NO.91, ss 304

*P6566 are ZZ Bearings. *P6686 are S/Steel RS Bearings.

18 END STOP NO.73

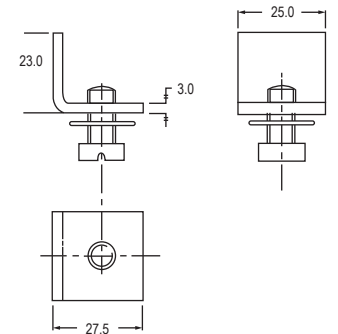

PART NO.	DESCRIPTION
P6564	END STOP NO.73
P6690	END STOP NO.73, ss 304

SYSTEM 70/90 AT ITS BEST

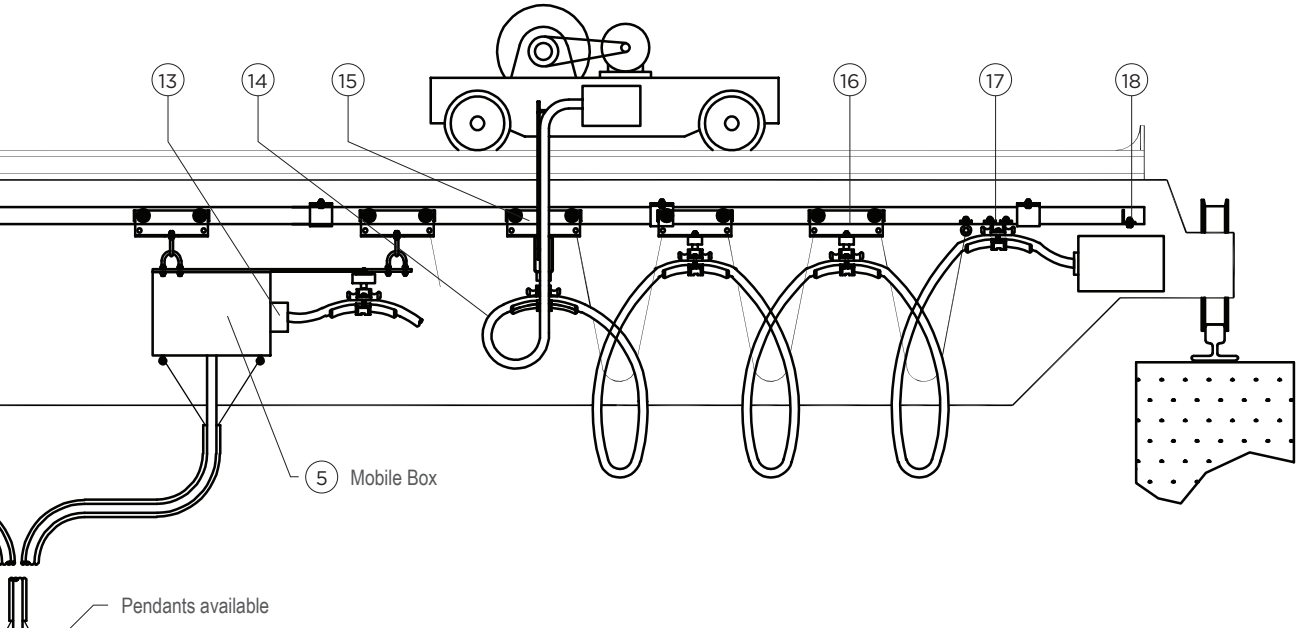

9 MOBILE BOX NO.151

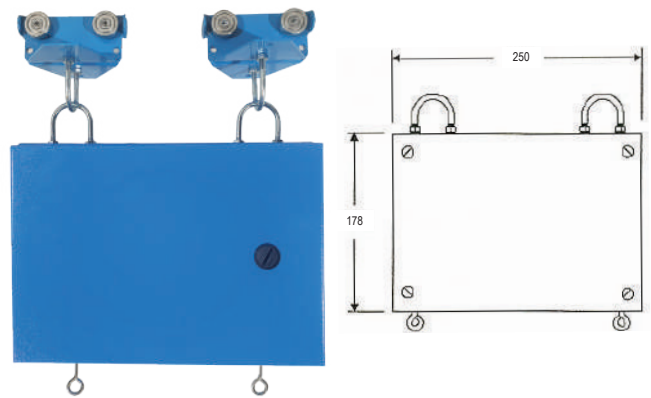

PART NO.	DESCRIPTION
P6573	Mobile box, c/wUBOLT+2 NO.90
P6796	Mobile box, c/wUBOLT+2NO.90ss

1 C-TRACK NO.70

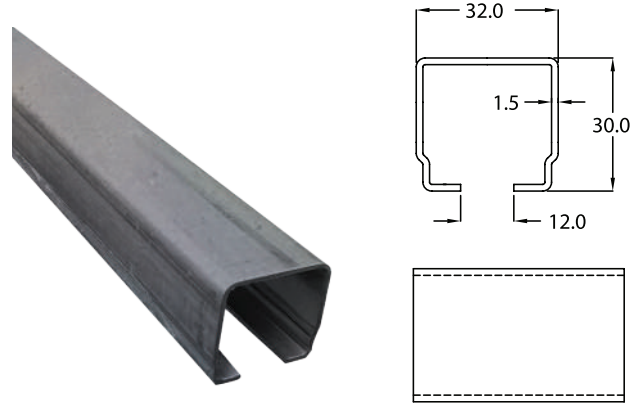

PART NO.	DESCRIPTION
P6561	C RAIL TRACK GALV. NO.70
P6560	C-RAIL TRACK NO.70ss

*5m lengths only.

2 SUSPENSION BRACKETS

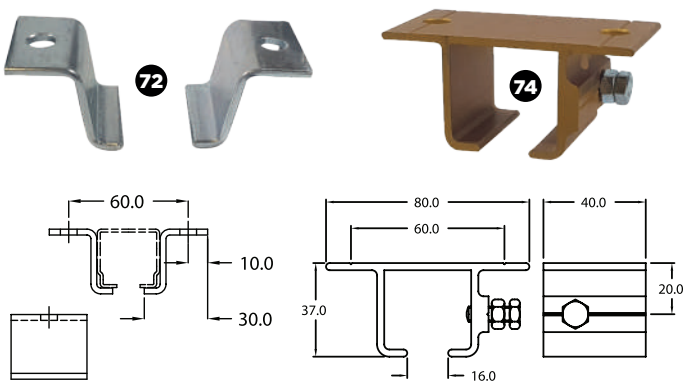

PART NO.	DESCRIPTION	PART NO.	DESCRIPTION
P6563	SUSPENSION CLAMP, split NO.72	P6604	SUSPENSION CLAMP, solid NO.74
P6689	SUSPENSION CLAMP, split NO.72, SS 304		

10 TRACK JOINT NO.71

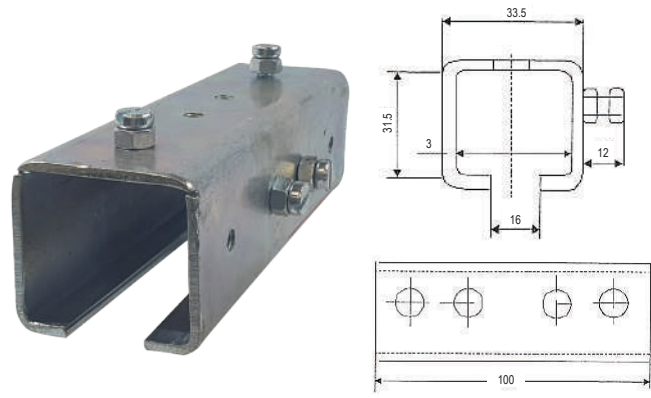

PART NO.	DESCRIPTION
P6562	RAIL JOINT NO.71
P6688	RAIL JOINT NO.71, ss 304

C-TRACK LIGHT DUTY PVC FESTOON SYSTEM - PARTS NO. 70/40

1 END STOP NO.73

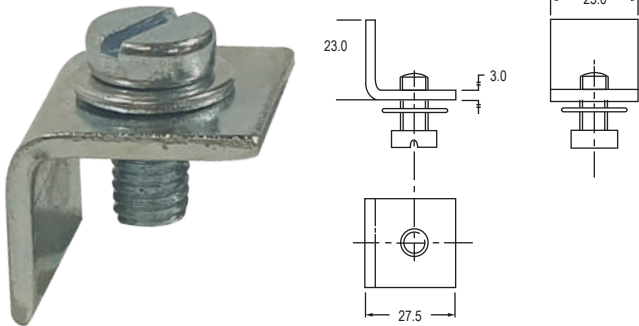

PART NO.	DESCRIPTION
P6564	END STOP NO.73
P6690	END STOP NO.73, ss 304

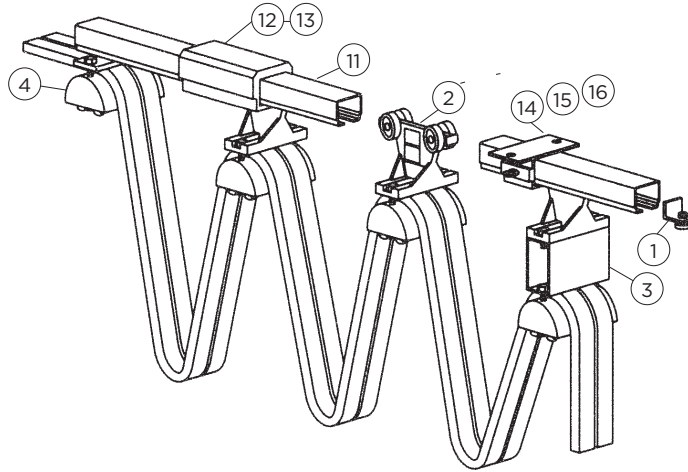

Required Flatcable length = Track length + 10% + 2 Tails @ V = 30m/min
Required Roundcable length = Track length + 15% + 2 Tails @ V = 30m/min

5 MOBILE BOX NO.151/40

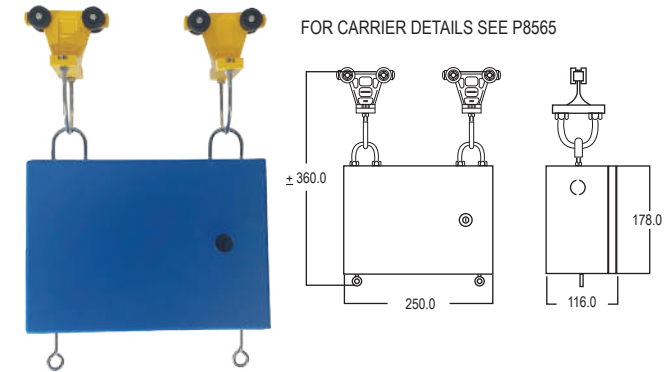

PART NO.	DESCRIPTION
P8573	MOBILE BOX c/w 2-PVC CARRIER 40

2 CABLE CARRIER NO.40

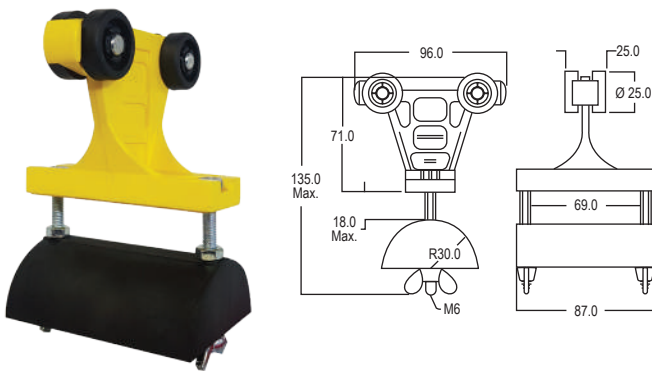

PART NO.	DESCRIPTION
P8565	PVC FL-CABLECARRIER No40, yellow

3 MASTER CARRIER NO.41

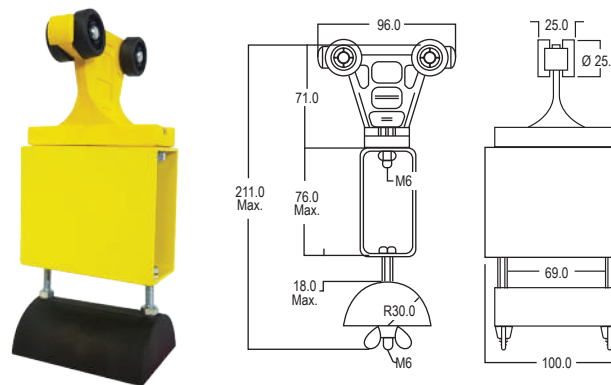

PART NO.	DESCRIPTION
P8566	PVC FLAT MASTER CARRIER No41, yellow

4 END CLAMP NO.42

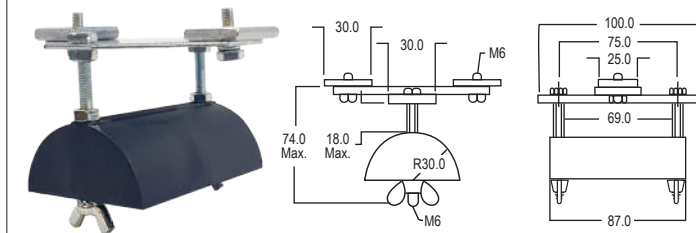

PART NO.	DESCRIPTION
P8567	PVC FLAT ENDCLAMP No42, black

1 C-PROFILE TRACK NO.240

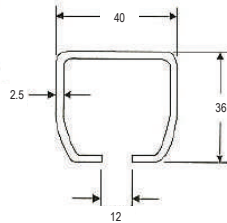

PART NO.	DESCRIPTION
P8050	H.D.C-RAIL TRACK GALV. NO. 240
P10070	C-RAIL TRACK NO.240ss

* 5m lengths only

2 SUSPENSION CLAMP NO.242

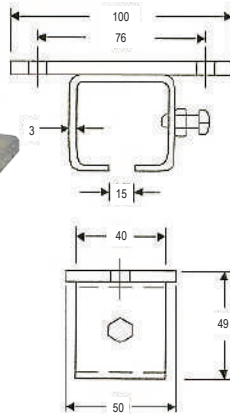
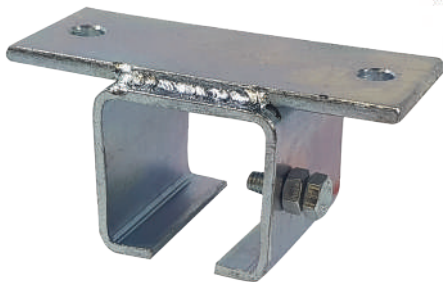

PART NO.	DESCRIPTION
P8052	H.D. SUSPENSION CLAMP NO.242
P10075	H.D. SUSPENSION CLAMP NO.242 ss 304

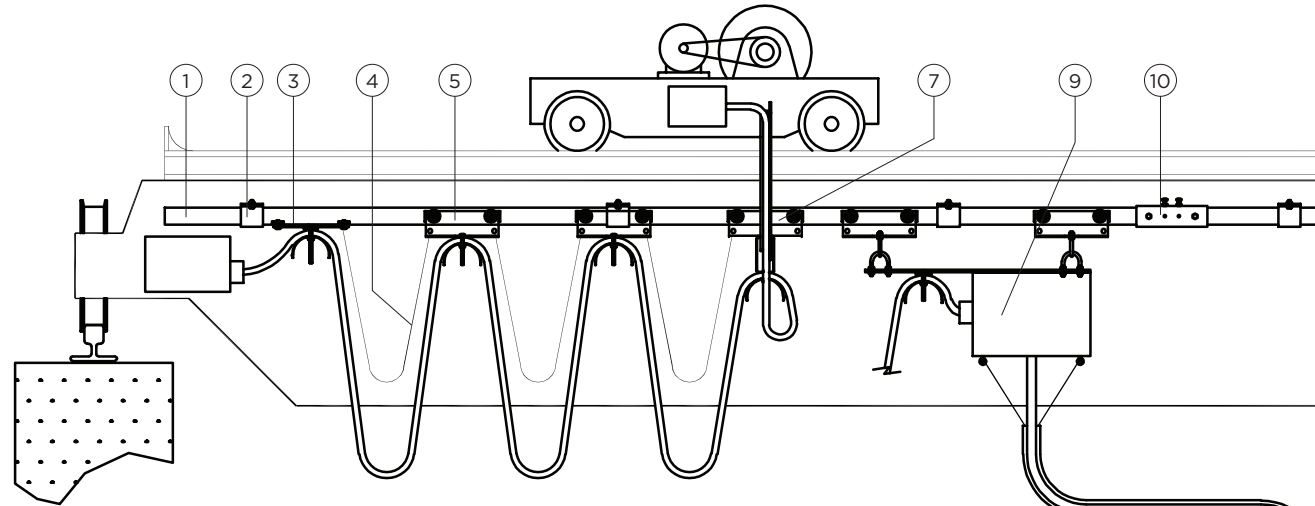

Item 6 Cable length = track length + 10% + 2 tails at V - up to 40 m/min. Item 5 Carrier quantity is to be based on system length + loop depth.

10 RAIL JOINT NO.241

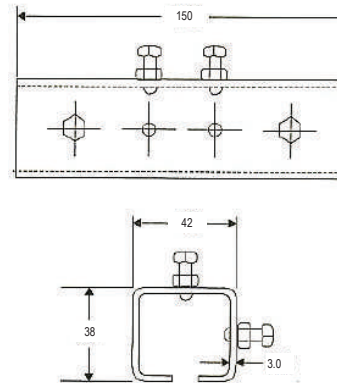

PART NO.	DESCRIPTION
P8051	H.D. RAIL JOINT NO.241
P10074	RAIL JOINT NO.241, ss 304

9 MOBILE BOX NO.151

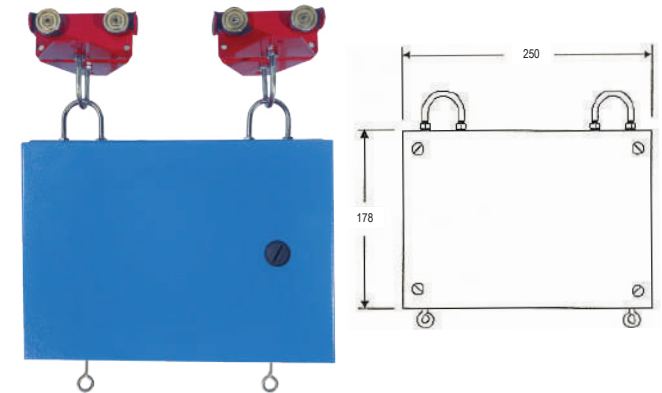

PART NO.	DESCRIPTION
P8079	MOBILE BOX c/wUBOLT+2XNO250/21
P10078	MOBILE BOX c/wUBOLT+2XNO250/21, ss 304

*P8079 are ZZ Bearings. *P10078 are S/Steel RS Bearings.

The Festooning arrangements, as depicted above, are showing all parts normally required to operate a Loopsystem to feed Cranes, Hoists, Conveyors or other mobile users **with all varieties of energy i.e. electricity - hydraulics - pneumatics - optics**

N.B. Cable Carrier No. 250 can carry 30kg of load - parking space equals 160mm x no. of carriers - approx. travel speed of system V = 100 m/min - Item 1 C-Track length 5m - Item 2 Suspension clamp spacing 2m. As this Festooning is used in a variety of applications and environments, which require special designs and particular material, POWERMITE has developed additional suitable parts within the No. 240/250 System which cannot all be shown in this publication. Please let us attend to your special enquiries to satisfy your demands!

SYSTEM 240/250 AT ITS BEST

POWERMITE

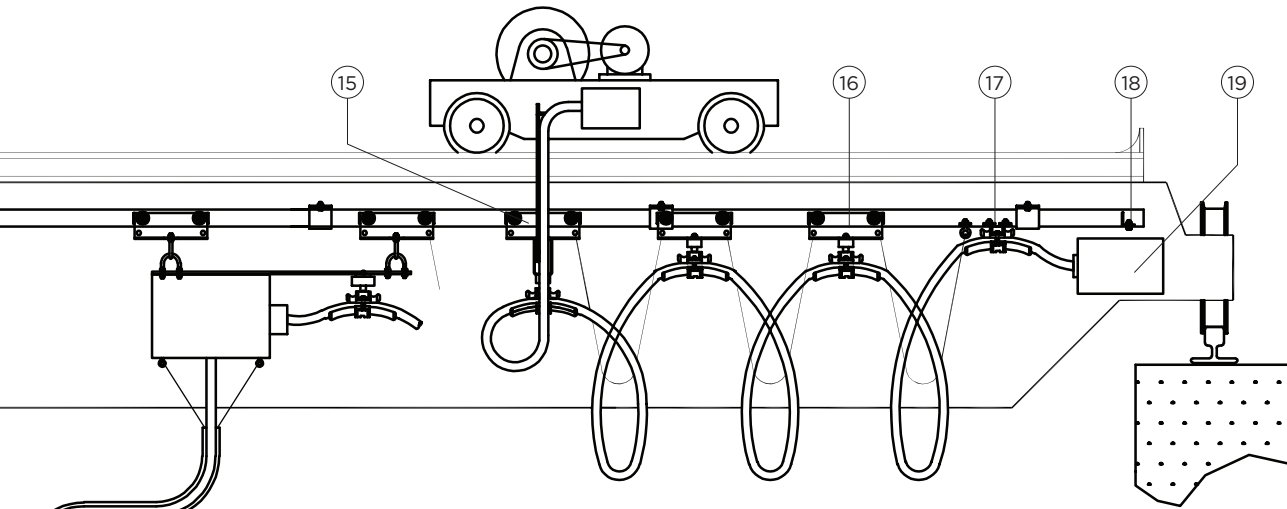

Pendants available

Item 14 Cable length = track length + 15% + 2 tails at V - up to 40 m/min. Item 16 Carrier quantity is to be based on system length + loop depth.

3 END CLAMP NO.252

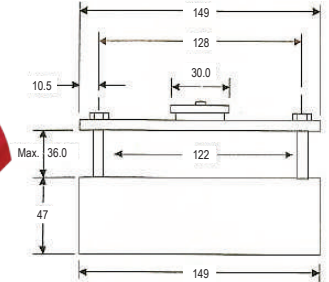

PART NO.	DESCRIPTION
P8055	H.D. FLAT END CLAMP NO.252
P10073	FLAT CABLE END CLAMP NO.252, ss 304

5 CABLE CARRIER NO.250

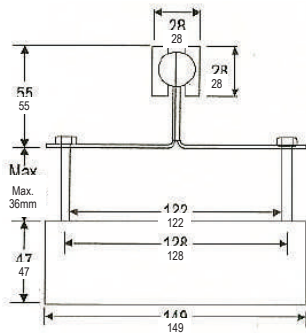
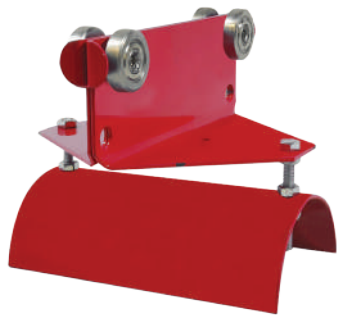

*P8053 are ZZ Bearings. *P10071 are S/Steel RS Bearings.

PART NO.	DESCRIPTION
P8053	H.D. FLAT CABLE CARRIER NO.250
P10071	FLAT CABLE CARRIER NO.250, ss 304

7 MASTER CARRIER NO.251

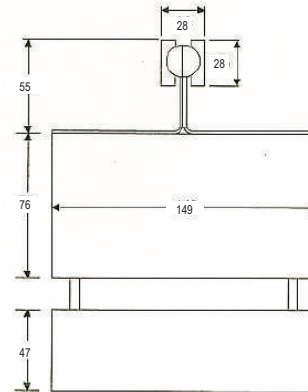

*P8054 are ZZ Bearings. *P10072 are S/Steel RS Bearings.

PART NO.	DESCRIPTION
P8054	H.D. FLAT MASTER/CARRIER NO.251
P10072	FLAT MASTER CABLE CARRIER NO.251, ss 304

15 16 17 ROUND CABLE CARRIER

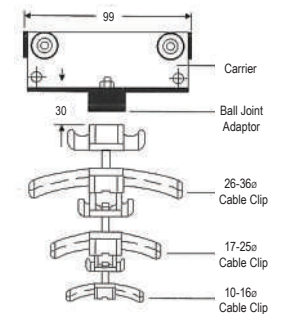

Use the ball joint to suit hose & round cable applications.

PART NO.	DESCRIPTION
P6881	BALL JOINT
P6757	26 - 36 mm CABLE CLIP
P6756	17 - 25 mm CABLE CLIP
P6755	10 - 16 mm CABLE CLIP

Head Office
☎ +27 11 271 0000
✉ info@powermite.co.za

Witbank
☎ +27 13 692 3448/9
✉ powermite.witb@powermite.co.za

Cape Town
☎ +27 21 951 1505
✉ powermite.ct@powermite.co.za

Rustenburg
☎ +27 14 592 2209
✉ powermite.rburg@powermite.co.za

Richards Bay
☎ +27 35 751 1213/6
✉ powermite.rbay@powermite.co.za

Pinetown
☎ +27 31 700 6830/4
✉ powermite.dbn@powermite.co.za